



Designation: D1461 – 17

Standard Test Method for Moisture or Volatile Distillates in Asphalt Mixtures¹

This standard is issued under the fixed designation D1461; the number immediately following the designation indicates the year of original adoption or, in the case of revision, the year of last revision. A number in parentheses indicates the year of last reapproval. A superscript epsilon (ϵ) indicates an editorial change since the last revision or reapproval.

This standard has been approved for use by agencies of the U.S. Department of Defense.

1. Scope

1.1 This test method covers the determination, by direct measurement, of moisture or volatile fractions of the asphalt in asphalt mixtures.

1.2 The values stated in SI units are to be regarded as the standard. No other units of measurement are included in this standard.

1.3 The text of this standard references notes and footnotes which provide explanatory material. These notes and footnotes (excluding those in tables and figures) shall not be considered as requirements of the standard.

1.4 *This standard does not purport to address all of the safety concerns, if any, associated with its use. It is the responsibility of the user of this standard to establish appropriate safety and health practices and determine the applicability of regulatory limitations prior to use.*

1.5 *This international standard was developed in accordance with internationally recognized principles on standardization established in the Decision on Principles for the Development of International Standards, Guides and Recommendations issued by the World Trade Organization Technical Barriers to Trade (TBT) Committee.*

2. Referenced Documents

2.1 *ASTM Standards:*²

D979/D979M Practice for Sampling Bituminous Paving Mixtures

D3666 Specification for Minimum Requirements for Agencies Testing and Inspecting Road and Paving Materials

D6997 Test Method for Distillation of Emulsified Asphalt

¹ This test method is under the jurisdiction of ASTM Committee D04 on Road and Paving Materials and is the direct responsibility of Subcommittee D04.25 on Analysis of Asphalt Mixtures.

Current edition approved June 1, 2017. Published June 2017. Originally approved in 1956. Last previous edition approved in 2011 as D1461 – 11. DOI: 10.1520/D1461-17.

² For referenced ASTM standards, visit the ASTM website, www.astm.org, or contact ASTM Customer Service at service@astm.org. For *Annual Book of ASTM Standards* volume information, refer to the standard's Document Summary page on the ASTM website.

3. Significance and Use

3.1 This test method is used for determining either the amount of moisture or the amount of volatile petroleum distillates in asphalt mixtures.

3.2 Applicable standards are those in which measurements or calibrations are made, samples are procured, or products are selected.³

4. Apparatus

4.1 *Metal Still*—A vertical cylindrical still, similar to that used in Test Method D6997, having a faced flange at the top to which the head is tightly attached by means of a clamp. The head shall be of metal, preferably of copper or brass, and shall have a tube opening of 25.4 mm of inside diameter to facilitate attachment of the specified trap/condenser assembly.

4.2 *Condenser*, of the water-cooled reflux glass-tube type, having a condenser jacket not less than 400 mm long with an inner tube 9.5 to 12.7 mm in outside diameter. The end of the condenser inserted in the trap shall be ground off at an angle of 30° from the vertical axis of the condenser. For mixtures with very volatile solvents, it may be necessary to supplement this water-cooled condenser with a second water-cooled condenser of approximately the same dimensions.

4.3 *Trap*, of well-annealed glass, of one of the following types depending upon the purpose of the test:

4.3.1 For determination of water in asphalt mixtures, a glass trap of 10- or 25-mL capacity shall be used. The trap shall be graduated in 0.1-mL divisions with ± 0.05 -mL maximum error below 1 mL, and in 0.2-mL divisions with a ± 0.1 -mL maximum error above 1 mL, as specified in Table 1 and Figs. 1-4. Tapered ball traps require adaptors for connection to the metal still.

³ The quality of the results produced by this standard are dependent on the competence of the personnel performing the procedure and the capacity, calibration, and maintenance of the equipment used. Agencies that meet the criteria of Specification D3666 are generally considered capable of competent and objective testing, sampling, inspection, etc. Users of this standard are cautioned that compliance with Specification D3666 alone does not completely ensure reliable results. Reliable results depend on many factors; following the suggestions of Specification D3666 or some similar acceptable guideline provides a means of evaluating and controlling some of those factors.

TABLE 1 Dimensions and Sizes of Traps

Style	Description			Figure	Size of Trap, mL	Range, mL	Small-est Scale Division, mL	Scale Error max, mL
	Top of Graduated Tube	Bottom of Graduated Tube	Bottom of Vapor Tube					
A	§ joint	conical	§ joint	7	10	0 to 1.0 over 1.0 to 10.0	0.1 0.2	0.05 0.1
B	§ joint	conical	§ joint	8	25	0 to 1.0 over 1.0 to 25	0.1 0.2	0.05 0.1
C	§ joint	conical	plain	9				
D	plain	conical	plain	10				
E	§ joint	round	§ joint	11	5 10	0 to 5.0 0 to 10.0	0.1 0.1	0.05 0.1

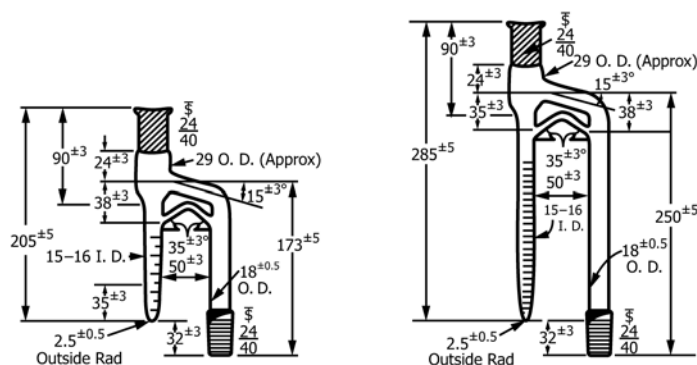

NOTE 1—All dimensions are in millimetres.

FIG. 1 Traps (Style A)

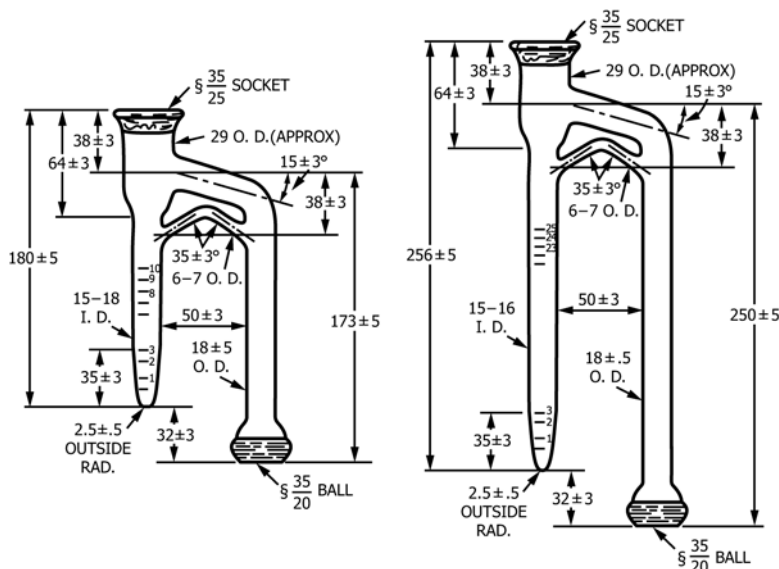

NOTE 1—All dimensions are in millimetres.

FIG. 2 Traps (Style B)

4.3.2 For determination of the volatile fractions of the asphalt, the trap shall conform to the dimensions shown in Fig. 5.

4.4 Solvent—For general use, an aromatic solvent is preferred, since it has high solvency and dispersing power for most asphalt materials. Xylene, or a blend of 20 % toluene and 80 % xylene, is recommended. For asphalts and similar petro-

leum products, a petroleum distillate, 5 % boiling between 90 and 100 °C, and 90 % distilling below 210 °C may be used. For coal tar, water-gas tar, and similar materials, the aromatic solvent must be used.

4.5 Heating Device— Any satisfactory source of heat that will be capable of maintaining a rate of distillation of 85 to 95 drops/min.